



CUSTOM TOOLS

CHAPTER 1

Custom Shop

Horotec SA has been active since 1946 in the field of quality watchmaking supplies and tools. The company distributes 14,000 references in tools and 85,000 in repair components throughout the Swiss and foreign watch industry.

With its custom shop, Horotec wants to break the traditional codes of watchmaking tools. This custom shop, launched by Horotec, targets a watchmaking clientele who wants to use Swiss quality tools with a touch of originality. These are new, limited edition tools that this shop will offer. By chapter, we will find different accessories with original patterns, different colors and reinvented textures.

Founded in La Chaux-de-Fonds within this watchmaking heritage, it is with importance that Horotec will favor the know-how of local craftsmen. With their knowledge and experience, they will contribute to revisiting watchmaking tools. Different techniques will be used to create these novelties. We can cite waterpainting, guillochage, engraving, electroplating etc.

By offering unique products, Horotec wishes to bring together watchmaking professionals and enthusiasts around an innovative concept, following current trends.

Initially, Horotec will take care of the customization of its products but will remain open to collaborate on projects, to receive ideas or to requests for customization.

It is essential to involve our craftsmen in the manufacturing method of these new products. These products are all authenticated **Swiss Made**, thus affirming the quality of what we have been offering for years.

The trend of personalization exists for many products. Several brands are developing in this direction. Thus, we decided to bring this possibility in the sector of watchmaking tools.

The products that will be offered on this shop will be **in limited quantities** in order to distinguish them from our traditional products. In addition, the time spent by our craftsmen on each product does not allow mass production. The tool's function does not change, but its visual identity and physical appearance do.

We select quality materials, which allow our tools to last over time. An edition as we propose it must be able to exist in the future as a messenger of Swiss know-how.

Traditions are being lost and so is manual work. We do not only want to distinguish ourselves but to promote these professions which are tending to disappear. These are the professions that have allowed watchmaking to reach its level of quality, losing them would be a terrible mistake. We want the customer to perceive the watchmaking tools offered on this shop differently, as a tool perpetuating a tradition.

This also allows us to show that craftsmanship is not only intended for the watch but can also be found in the tool that designs it.

Other products will appear over time. As indicated, the importance is to promote, through different chapters, the manual trades of our craftsmen.

Thus, the first chapter will deal with the art of waterpainting. On our Custom Shop, you will find explanations about this manual process and a video presenting the craftsman.

In each chapter, you will discover the products, the explanation of the artisanal process as well as a video presentation.

It is important to note that for each of the chapters, Horotec remains open to discuss possible customizations that use the artisanal process of customization.

With the tools customized by Horotec, you will distinguish yourself from traditional watchmaking tools, you will show that you also attach importance to quality products which will be reflected in your work. To buy a custom Horotec product is to differentiate yourself and support the craftsmen of a region with internationally recognized know-how.

We decided to open this «Custom Shop» platform in order to offer derivatives of products sold by Horotec. This will distinguish the redesigned collection from traditional products. Thus, you will never find such products on the official Horotec webshop.

All products are available at our offices and can be presented to you.

CHAPTER 1

The art of waterpainting

The presses are flagship products of the after-sales service. It seemed important to us to start with such products.

The chosen editions are **Carbon, Magma, Wood** and **Grafiti**. With these themes, we address a varied audience and allow our stems to fit into different professional atmospheres.

Thus, the Wood will fit very well in a wooded atmosphere, at a watchmaker who places importance on natural materials. The Carbon version will be more attracted by the watchmaker who is passionate about sports competition.

Water painting :

Process using inks that resist the surface of water without mixing and that prints on the object that is dipped inside.

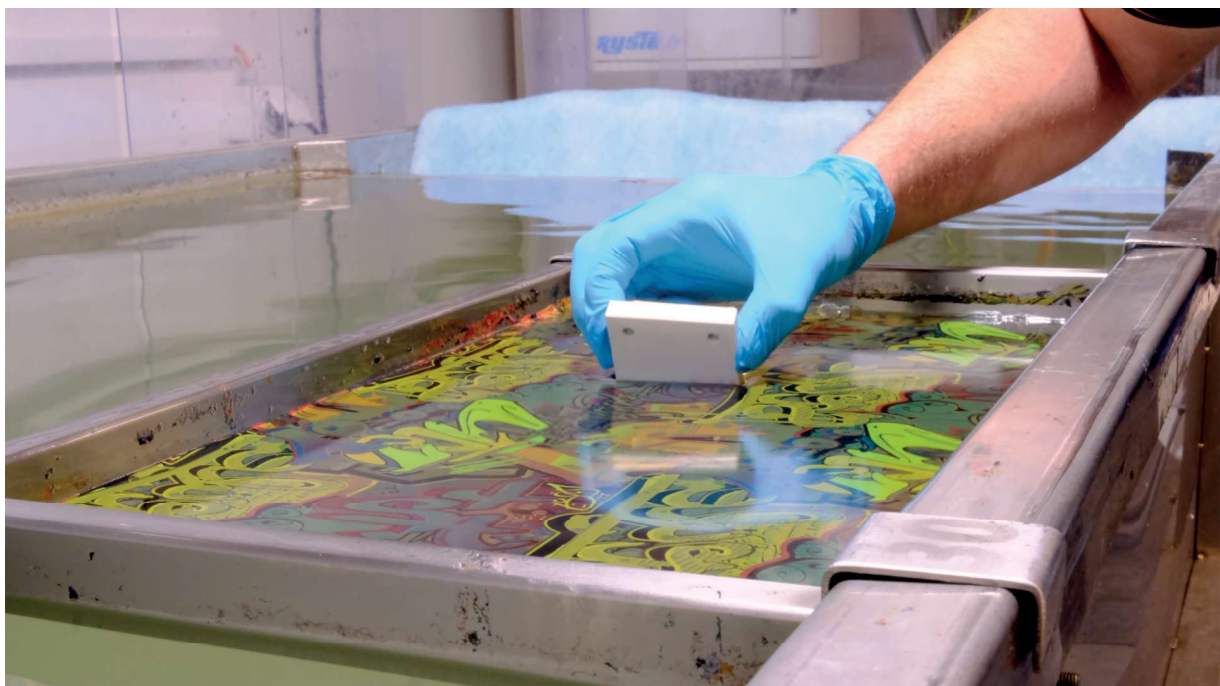

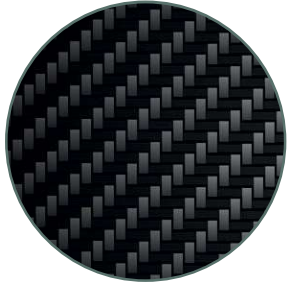

RENDER /
CARBON

AVAILABLE MODELS

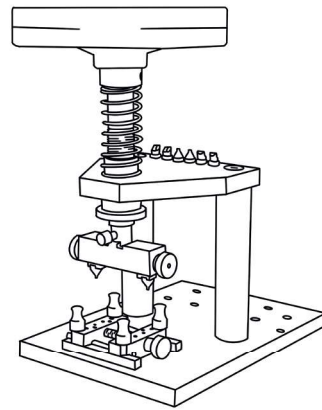

CARB07.360

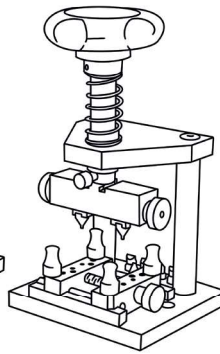

CARB07.320

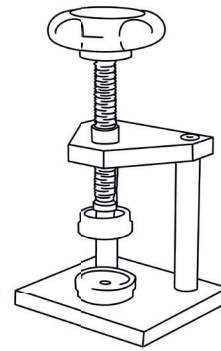

CARB07.131

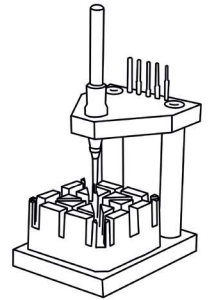

CARB10.499



REF	Size	Kg	CHF
CARB07.360	160 × 220 × 280 mm	5.035	663.00
CARB07.320	110 × 95 × 200 mm	1.900	382.75
CARB07.131	110 × 95 × 210 mm	1.575	307.25
CARB10.499	60 × 80 × 110 mm	0.415	151.90

"Each of the 4 presses is available in 75 units per edition and will include its serial number."



RENDER / WOOD

AVAILABLE MODELS

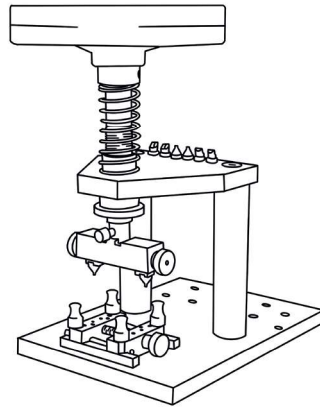

WOOD07.360

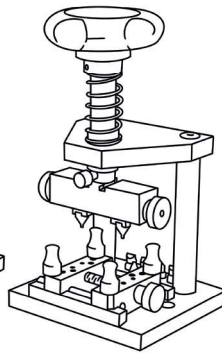

WOOD07.320

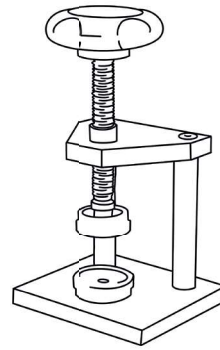

WOOD07.131

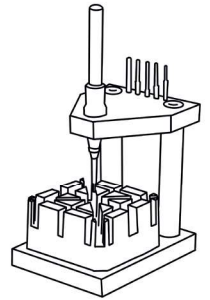

WOOD10.499



REF	Size	Kg	CHF
WOOD07.360	160 × 220 × 280 mm	5.035	663.00
WOOD07.320	110 × 95 × 200 mm	1.900	382.75
WOOD07.131	110 × 95 × 210 mm	1.575	307.25
WOOD10.499	60 × 80 × 110 mm	0.415	151.90

"Each of the 4 presses is available in 75 units per edition and will include its serial number"



RENDER /
MAGMA

AVAILABLE MODELS

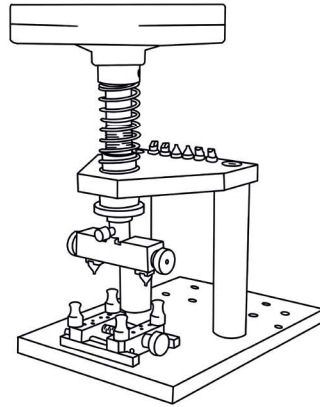

MAG07.360

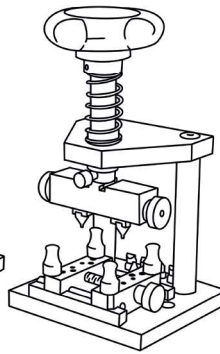

MAG07.320

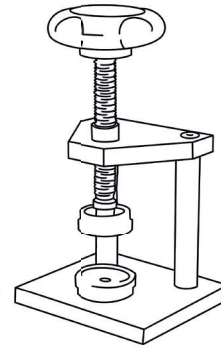

MAG07.131

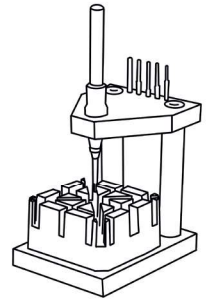

MAG10.499



REF	Size	Kg	CHF
MAG07.360	160 × 220 × 280 mm	5.035	663.00
MAG07.320	110 × 95 × 200 mm	1.900	382.75
MAG07.131	110 × 95 × 210 mm	1.575	307.25
MAG10.499	60 × 80 × 110 mm	0.415	151.90

"Each of the 4 presses is available in 75 units per edition and will include its serial number"



RENDER / GRAFFITI

AVAILABLE MODELS

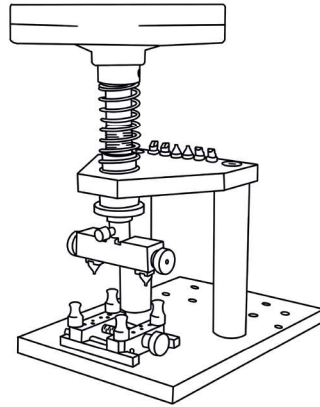

GRAF07.360

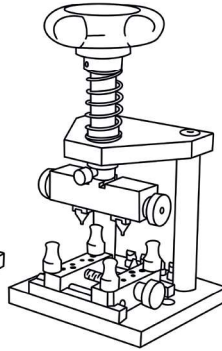

GRAF07.320

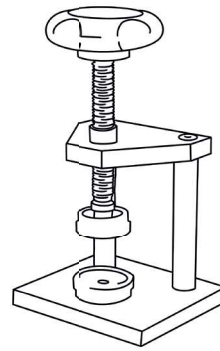

GRAF07.131

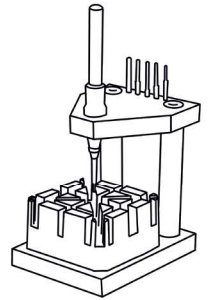

GRAF10.499



REF	Size	Kg	CHF
GRAF07.360	160 × 220 × 280 mm	5.035	663.00
GRAF07.320	110 × 95 × 200 mm	1.900	382.75
GRAF07.131	110 × 95 × 210 mm	1.575	307.25
GRAF10.499	60 × 80 × 110 mm	0.415	151.90

"Each of the 4 presses is available in 75 units per edition and will include its serial number."

CARBON
EDITION

WOOD
EDITION

www.horotec-custom.ch

MAGNUM
EDITION

GRAFFITI
EDITION

HOROTEC SA
Av. Léopold-Robert 105b
2300 La Chaux-de-Fonds
SWITZERLAND

T. +41 32 925 95 95
F. +41 32 925 95 96
swiss@horotec.ch

T. +41 32 911 21 21
F. +41 32 911 21 22
export@horotec.ch

 [horotecsuisse](https://www.facebook.com/horotecsuisse)

www.horotec.ch

NOS MARQUES :

HOROTEC
SWISS

L'outil Horloger...

PRECITEC
QUALITY

HoroSwiss
SWISS MADE

SWISS METROLOGIE

ARY

CUSTOM CHAPTER 1 P.8